

MAXIPLANK

LAP SIDING INSTALLATION GUIDE



Read all instructions prior to installing any siding product. Failure to install and finish this product in accordance with all local building codes, regulations and MaxiTile written application may lead to personal injury, affect system performance, violate local building codes, and void the product warranty. We suggest that you read these instructions at least twice.

MAXIPLANK is available with several different surface textures: Classic Cedar, Traditional Cedar and Smooth in three designs: Classic, Colonial and Provenzal. **MAXIPLANK** is 12' in length with widths of 5 1/4", 6 1/4", 7 1/4", 8 1/4", 9 1/4" and 12".

MAXIPLANK is fiber-cement exterior lap siding. It will not rot or deteriorate. It is non-combustible with zero flame spread and zero smoke generation.

Storage and Handling:

- Protect from the weather.
- Use the plastic cover that is provided in pallet to keep dry the product.
- **MAXIPLANK** siding comes with factory primer, even this, the plank could become wet or saturated if it is not protected during storage. If **MAXIPLANK** becomes wet or saturated, do not install it until it dries out.
- Store product dry and flat prior to installation
- Installing **MAXIPLANK** wet or saturated may cause shrinkage at butt joint, which could produce breakage at corners.
- Protect edges and corners from chipping.
- Carry planks on edge.

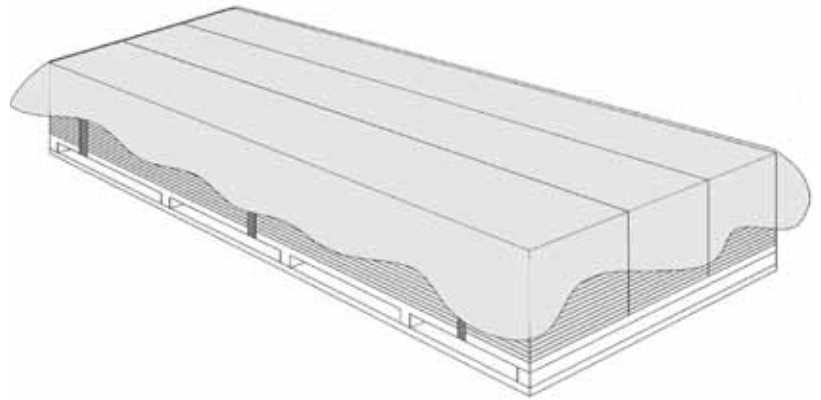

MaxiTile is not responsible for damage caused by improper storage and handling of the product.

IMPORTANT: To prevent damage to the drip edge, extra care should be taken when removing planks from the pallet, while handling, and when installing with a lap gauge. Please see additional handling requirements:

- Planks are interlocked together on the pallet, therefore they should be removed from the pallet horizontally (side to side) to allow planks to unlock themselves from one another.
- Pull from across the stack. Do not go down the stack.

Framing :

- Follow local building code for proper framing and flashing requirements.

- **MAXIPLANK** can be installed over braced wood or steel studs, spaced at 16" with max. 24" o.c. or directly to minimum 7/16" thick OSB sheathing. Irregularities in framing and sheathing can mirror through the finished application.
- Concealed nailing is not allowed at 24" on center, or when installing 12" wide siding at 16" o.c.
- A weather resistant barrier between the framing and the siding is required in accordance with local building code requirements. The water resistive barrier must be appropriately installed with penetration and junction flashing in accordance with local building code requirements.
- Do not use **MAXIPLANK** lap siding in Fascia or Trim applications.
- Do not install MaxiTile products, such that they may remain in contact with standing water.
- **MAXIPLANK** lap siding may be installed on flat vertical applications only.
- DO NOT use stain on MaxiTile products.

MaxiTile will not assume any responsibility for water infiltration within the wall or wall cavity.

Cutting:

- If power-sawing use carbide- or diamond- tipped blade. Position cutting station so that wind will blow dust away from user and others in working area.
- Wear NIOSH approved respirators and goggles for protection when power-sawing.
- For score-and-snap cutting, use a carbide-tipped scoring tool.
 - Using a straight edge as a guide, carefully draw the scoring tool several times towards yourself, applying even pressure.
 - Bend upwards and break.
- Snapper tools and shears can also be used.
- Round openings can be made by drilling several holes around circumference of the desired opening and tapping out the center.
- NEVER use a power saw indoors.
- NEVER dry sweep-use wet suppression or HEPA vacuum.

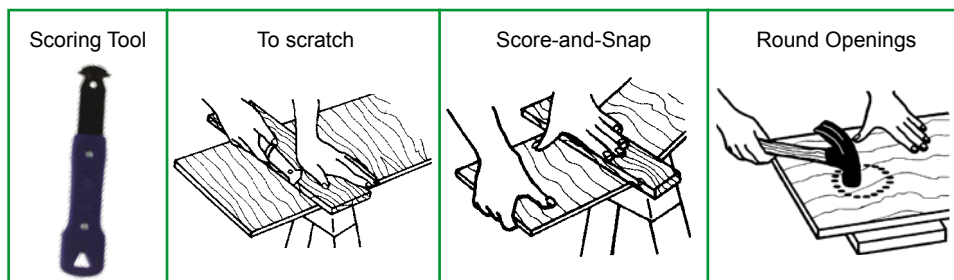

WARNING: AVOID BREATHING SILICA DUST.

MaxiTile siding products contain respirable crystalline silica, which is known to the State of California to cause cancer and is considered by IARC and NIOSH to be a cause from some occupational sources. Breathing excessive amounts of respirable silica dust can also cause a disabling and potentially fatal lung disease called silicosis, and has been linked with other diseases. Some studies suggest smoking may increase these risks. During installation or handling: (1) work in outdoor areas with ample ventilation; (2) use fiber cement shears for cutting or, where not feasible, use a dust-reducing circular saw attached to a HEPA vacuum; (3) warn others in the immediate area; (4) wear a properly-

fitted, NIOSH-approved dust mask or respirator (e.g. N-95) in accordance with applicable government regulations and manufacturer instructions to further limit respirable silica exposures. During clean-up, use HEPA vacuums or wet methods, never dry sweep. For further information, refer to our installation guides and Material Safety Data Sheet available at www.maxitile.com or by calling (800) 338-8453. **FAILURE TO ADHERE TO OUR WARNINGS, MSDS, AND INSTALLATION GUIDES MAY CAUSE SERIOUS PERSONAL INJURY OR DEATH.**

Fastener:

Fasteners must be corrosion-resistant; preferably quality hot dipped galvanized nails. MaxiTile is not responsible for corrosion resistance of fasteners. Stainless steel fasteners are recommended when installing MaxiTile products near the ocean, or in very humid climates.

- Screws shall be self-drilling all weather or stainless steel.
- Staples are not allowed.
- To wood stud:
 - Nails must always hit studs, penetrating a min. of 1-inch into stud. If nail hit sheathing only, warranty may be voided.
 - Nails can be applied using a smooth head hammer or a pneumatic nail gun with flush attachment so that nails are not over-driven.
 - If you hand-nailing, pre-drill the holes at the corners to avoid accidental breakage.
 - Take special care when install **MAXIPLANK** over a non-nailable substrate, pre-drill the holes.
 - Concealed fastening: No. 11 x 2" long roofing nails, with min. 0.125" shank and 0.275" head. Exposed corners should not be face-nailed with concealed fastening.
 - Exposed fastening: 2" long 6-penny nails, with min. 0.125" shank and 0.265" head.
- To metal stud:
 - Concealed fastening: No. 8 x 1 1/4" long C-wing screws.
 - Exposed fastening: No. 8 x 1 5/8" long C-drill screws.
- Drive fasteners perpendicular to siding and framing.
- Do not over-drive nail heads or drive nails at an angle.
- If nail is countersunk, caulk nail hole and add a nail.

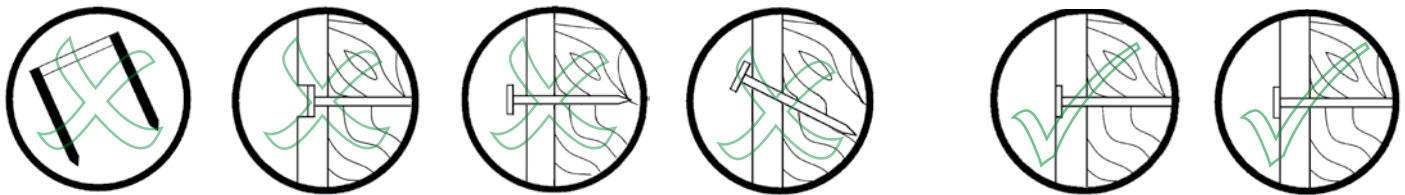

Remember : Fastener always must be attached to structural framing members.

NOTE: Published wind loads may not be applicable to all areas where Local Building Codes have specific jurisdiction. Consult MaxiTile Technical Assistance if you are unsure of applicable compliance documentation.

Clearances:

MaxiSiding products should be installed to meet local building code clearance requirements between the bottom edge of the MaxiSiding and adjacent finished grade. These clearances ensured the long-term durability of the products and the building on which they are installed. Failure to provide the proper clearances may void warranty on the products.

- Install siding and trim products in compliance with Local Building Code requirements for clearance between the bottom edge of the siding and the adjacent finished grade.
- Maintain a 1" - 2" clearance between MaxiTile products and paths, steps and driveways.
- Maintain a 1" - 2" clearance between MaxiTile products and decking material.
- At the juncture of the roof and vertical surfaces, flashing and counterflashing shall be installed per the roofing manufacturer's instructions. Provide a 1" - 2" clearance between the roofing and the bottom edge of the siding and trim.
- Maintain a 1/4" clearance between the bottom of MaxiTile products and horizontal flashing.
- Maintain a minimum 1" gap between gutter end caps and siding & trim.

Kickout Flashing:

Because of the volume of water that can pour down a sloped roof, one of the most critical flashing details occurs where a roof intersects a sidewall.

The roof must be flashed with step flashing. Where the roof terminates, install a kickout to deflect water away from the siding.

It is best to install a self-adhering membrane on the wall before the subfascia and trim boards are nailed in place, and then come back to install the kickout

Installation:

- Fasten metal or wood stops at all corners.
- Install a 1/4-inch thick starter strip level to the desired bottom of the first course by nailing to the sill plate.
- Locate and mark stud locations behind the weather barrier and sheathing to be sure that all nails will hit studs.
- Starting at an external corner and leaving 1/8" gap, install the first course level to the base of the starter strip. Butt the next **MAXIPLANK** with moderate contact to the preceding piece. Caulking at butt joints is optional. If caulking, make sure that the caulk completely fills the void. This can be ensured by applying caulk to the butt end of the first **MAXIPLANK** before installing the next piece, then lightly butting the next piece into it. At the end of the course, score-snap or cut the **MAXIPLANK** to fit. Leave 1/8" gap at all trim, windows and doors.
- To begin the next course use a self-aligning clip to set the lap at 1 1/4", which is the minimum allowed, lay in another clip at the other end of the **MAXIPLANK** for equal lap.
- Vertical joints are staggered a minimum of 16" from adjacent courses.
- All **MAXIPLANKS** must span over a minimum of two studs and shall butt over studs except when use the "off-stud-jointer"

All exposed field cut edges (such as butt joints, outside edges or where joint flashing is used), should be covered with primer, sealant or paint.

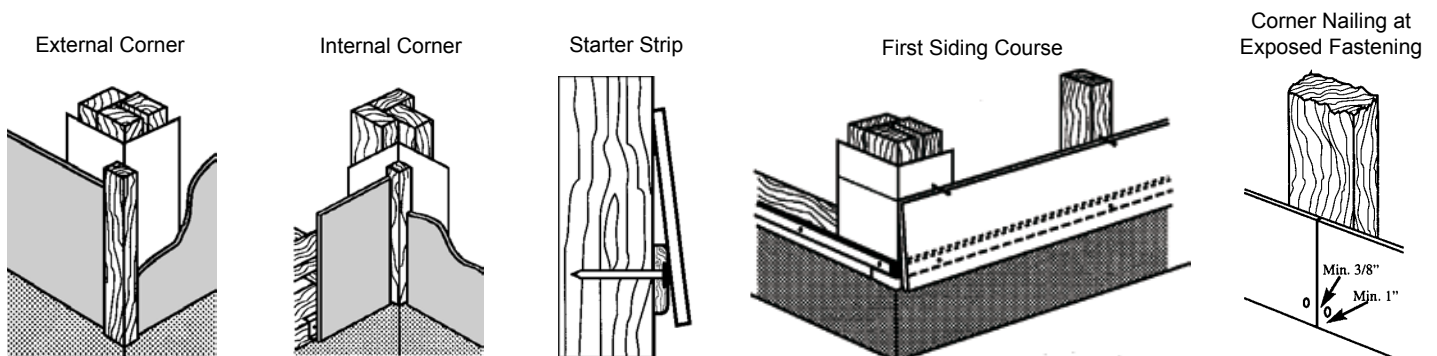

Concealed Fastening:

Fasteners are installed minimum 1-inch from the top edge of each plank with minimum of 1-inch penetration into all studs. It is important to keep nails level and low for tight siding. Hold siding snug to wall while nailing, especially at corners

Concealed Fastening

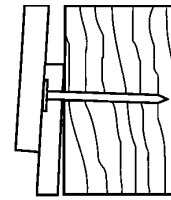

Exposed Fastening:

Fasteners are installed between ¾-inch and 1-inch from bottom edge of **MAXIPLANK**, with minimum of 1-inch penetration into all studs.

Exposed Fastening

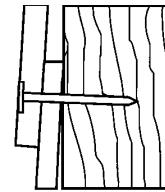

Off Stud Jointing:

This method is optional and can be used on any project. All wind load testing as reported in ICC-ESR-1381 was conducted using off-stud jointers.

The off-stud jointer is placed halfway onto the end of the plank with the flashing to the rear. The lower lugs are then positioned over the previous course. The **MAXIPLANK** is then fastened to all studs. Use of the off-stud jointer can eliminate up to 40% of cutting and 10% of waste. It ensures correct 1 ¼" lap, saves on saw blades, creates less dust and eliminates the risk for breakage at corners.

Off-Stud Jointer



Off-Stud Jointing System

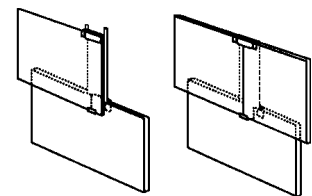

Finishing:

Patching:

- Repair chips and dents with acrylic patching mortar.
- Prime patched areas before coating.

Caulking:

- Use high quality exterior grade paint able elastomeric joint sealant, complying with ASTM-C 834 or ASTM-C 920 (grade NS, class 25). Caulking must be applied according to manufactures written instructions or ASTM C 1193.

Painting:

MaxiTile siding, soffit and trim must be allowed to breathe. Some factory-applied prime or paint on the back is normal, never completely prime or paint the back side, the product does not require this.

A small amount of material should be painted and evaluated to ensure satisfaction with the appearance before painting all material needed for job.

Never apply oil-based paints or stain to siding, soffit or trim, the use on unprimed or primed product could result in increase surface roughness, loss of adhesion, cracking or excessive chalk. Stains containing linseed oil are specifically designed for woods and not be suitable for fiber-cement products, primer or unprimed.

MaxiTile neither does nor recommended semi-transparent stain or paint because they can vary in uniformity of appearance and they have not proven durable in exterior exposure and may require application of a refurbishing sealer at regular intervals.

Before applying the finish coat, clean all the fiber-cement products thoroughly. Use a high-quality 100% acrylic paint or primer. Always follow the paint manufacturer's instructions when painting.

If you desire stained fiber-cement product, uses a high-quality 100% acrylic latex stain. Before stained test in small amount of material should be stained and evaluated to ensure satisfaction. Always follow the stain manufacturer's instructions when staining.

All fiber-cement products must be painted once installation, you have up 90 days (3 months) to apply a finish coat on unprimed products and 180 days (6 months) on primed products. For best result with unprimed products, prime first and then finish with exterior-grade topcoats, two coats of paint must be applied on primed products.

Remember all exposed field cut edges should be covered with primer, sealant or paint, the caulk/sealant should be paintable or color matched, it should be compatible with maxitile siding and the material used for the trim.

Never apply primer or paint to wet or saturated fiber-cement products. Do not allow paint to freeze. Apply primer or paint when temperature the air and the fiber-cement product is above 50°F (10°C).

MaxiTile will not warrant and does not assume any responsibility for the performance or appearance of field-applied primer and/or paint.

APPROVALS: In accordance with ICC-ES Legacy Report ESR-1381, MaxiPlank lap siding is compliance with the following codes: 2006 International Building Code (IBC) and 2006 International Residential Code (IRC) . MaxiPlank lap siding is also recognized for application in the following: City of Los Angeles Research Report No. 25252, State of Florida listing FL # 11009, U.S. Dept. of HUD Materials Release 1338, Texas Department of Insurance Product Evaluation EC-56, and listing in Wildland Urban Interface Handbook (WUI). These documents should also be consulted for additional information concerning the suitability of this product for specific applications.
Additional Installation Information, Warranties, and Warnings are available at www.maxitile.com

Maximum Wind Loads 5/16 inch Thick MaxiPlank

WIDE (inches)	FASTENER SPACING	FRAME TYPE	STUD SPACING (inches)	HEIGHT OF BUILDING (feet)	MAXIMUM BASIC WIND SPEED (mph) FOR EXPOSURE CATEGORY ¹											
					IBC, IRC ²			BNBC ³			SBC ⁴			UBC ⁵		
					B	C	D	B	C	D	< 60 ft	C	D	B	C	D
max. 12	No. 11 gage 2.087 inch long galvanized roofing nails	2 by 4 Wood	16	15	125	100	85	125	85	70	95	--	--	105	80	70
				20	120	100	85	105	80	70	90	--	--	100	80	70
				40	110	90	--	100	75	--	80	--	--	90	75	--
				60	105	85	--	90	70	--	75	--	--	85	70	--
				100	--	--	--	75	--	--	--	--	--	--	--	--
max. 9 1/2	No. 11 gage 1 3/4 inch long galvanized roofing nails	2 by 4 Wood	16	15	130	100	85	150	105	85	95	--	--	110	80	70
				20	120	100	85	145	105	80	90	--	--	--	80	70
				40	115	90	--	125	85	80	80	--	--	--	75	--
				60	110	85	--	115	80	75	75	--	--	--	70	--
				100	100	--	--	95	75	--	--	75	--	--	--	--
max. 9 1/2	No. 8 by 1 5/8 inch long RPI C/drill screws	No. 20 gage by 3 5/8 inch by 1 5/8 inch metal C/stud	16, 24	15	140	120	105	120	80	70	115	--	--	120	100	85
				20	140	120	100	115	80	--	110	--	--	120	100	80
				40	140	110	100	100	70	--	100	--	--	120	90	80
				60	130	105	90	90	70	--	90	--	--	110	85	75
				100	120	100	75	75	--	--	--	--	--	100	80	70
max. 9 1/2	No. 8 by 1 1/4 inch long RPI C/drill screws	No. 20 gage by 3 5/8 inch by 1 3/8 inch metal C/stud	16, 24	15	120	90	--	120	80	70	85	--	--	100	75	--
				20	110	85	--	115	80	--	80	--	--	90	70	--
				40	105	--	--	100	70	--	75	--	--	85	--	--
				60	100	--	--	90	70	--	70	--	--	80	--	--
				100	85	--	--	75	--	--	--	--	--	70	--	--

- 1 N/A - not applicable
- 2 Basic wind speed is the 3-second gust, miles per hour (km/hr), in accordance with IBC Section 1609.3 and IRC Section R301.2.
- 3 Basic wind speed is the fastest mile speed in accordance with BNBC Section 1609.3.
- 4 Basic wind speed is the fastest mile speed in accordance with SBC Section 1606.
- 5 Basic wind speed is the fastest mile speed in accordance with UBC Section 1616.
- 6 No. 11 gage nails has 0.125 inch diameter shank and 0.385 inch diameter head
- 7 No. 11 gage galvanized roofing nail has 0.120 inch diameter shank and 0.385 inch diameter head.

<p>MaxiTile, Inc. 849 East Sandhill Avenue Carson, CA 90746 Ph: 310/217-0316 Fax: 310/515-6851</p>	 <p>MAXITILE™ ... Long-Lasting Durability</p>	<p>Email: customer.service@maxitile.com</p> <p>Website: www.maxitile.com</p>
<p>1-800-338-8453</p>		